

## Standard Features :

- Removable top (some model)
- Heavy duty drive system
- Cool down
- Galvanized basket
- Sealed ball bearings
- Cast Iron pulleys
- Durable mark resistant powder-coated cabinet
- Large door opening
- Digital Timer Control (DTC)

## Optional Features :

- Microprocessor control
- Reversing cylinder (standard on DE100-DE200)
- Rotational sensor
- Humidity sensor
- Steam heated, Electrical heated, and Gas heated
- Energy-Saving Insulation
- Stainless steel basket
- Stainless steel front or full cabinets
- Stainless Steel Lint Filter
- Air re-circulating system (standard on IHDE100-IHDE200)



# Tumble Dryer

## IHDE Series

MODEL : IHDE-35, IHDE-50, IHDE-75,  
IHDE-100, IHDE-120, IHDE-150,  
IHDE-170, IHDE-190, IHDE-200



# IHDE Series

The Ironhorse IHDE Series - Economy High Efficiency Dryers for General Laundry Applications and Small to Medium Size On-Premise Laundries

## Discover the Benefits - Safe Reliable and Simple to use at an Affordable Price

The IHDE Series dryer offers a wide selection of capacities, heating alternatives and control systems. It is the ideal dryer for self-service laundries and medium to large size professional laundries.

The dryers will boost your productivity and at the same time save energy. You will get more for every Btu or kilowatt used. The robust design and the ergonomically located control panels will provide a long life of tough handling. The large doors on all models make loading and unloading easy.

### *Simple Microprocessor Control*

All dryers can be provided with our flexible and simple microprocessor. With a button you have total control over the dryer for optimum drying. The microprocessor monitors the temperatures, drying action and the performance with unsurpassed accuracy to ensure trouble free operation. The alphanumeric display is large and easy to read. A cool down and anti wrinkle feature keeps the machine in a cool down mode after the cycle has finished. The computer helps enhance safety in the laundry by verifying airflow and monitoring the temperature sensor and door.



### *Large Strong Door with Gasketless Door Glass*

The large door opens making loading and unloading easy. The door glass is attached to the door without a gasket providing a long lasting door that offers security and low maintenance over the life of the machine. The door is provided with a safety switch that will stop the machine when the door is opened. A simple magnetic latch keeps the door closed during operation.



### *Lint Filter and Lint Compartment*

A large lint screen or a lint drawer on larger models makes maintenance easy. It is accessible from the front and located close to the exhaust fan, preventing fan clog up and eliminating fan vibrations. The lint filter is efficient and provides good airflow that reduces the energy consumption. An indicator lamp in the control panel lights when it is time to clean the lint compartment.



# Economy High Efficiency Dryers

## *Built to Last Rugged Construction Insulated for Energy Efficiency*

The IHDE Series features a sturdy cylinder design with double sealed bearings and a quiet belt drive. The pulleys are cast iron for durability. A heavy base frame protects the machine during shipping and installation. The painted totally enclosed cabinet provides excellent protection against corrosion and utilizes heavy gauge steel and welded design that makes it stronger than any other dryer on the market. The cabinet is a fully enclosed design with insulation that improves efficiency by capturing radiant heat and retaining it inside the dryer. It also lowers the noise level and improves the working conditions inside your laundry. The drying cylinder is galvanized steel, or optionally, all stainless steel 304 (18/8).



## *Drive Motors*

All Motors are totally enclosed and fan cooled to prevent lint build-up. To prevent tangling, a reversing cylinder is standard on larger dryers.



## *Steam Heating*

Most steam-heated models are provided with a damper that allows the coil to stay constantly charged, eliminating repeated expansion and contracting. When the damper is open the air immediately passes through the already hot coil, providing instant heat to start the drying process. When the damper is closed, ambient air is drawn directly into the cylinder allowing for rapid cool down.



## *Gas Heating*

The gas-heated models are extremely efficient and boost productivity. The instantaneous ignition of the burners helps to achieve desired temperature quickly and efficiently. Heat is also evenly distributed as the airflow is directed into the cylinder with minimal loss. Felt seals are provided to reduce loss of air from the drying cylinder.



# SPECIFICATION

MODEL			IHDE-35	IHDE-50	IHDE-75	IHDE-100	IHDE-120	IHDE-150	IHDE-170	IHDE-190	IHDE-200
<b>Units of Measurement</b>	<b>Metric</b>	<b>US</b>									
Maximum Capacity (dry weight)	kg.	lbs.	15.87(35)	22.7(50)	34(75)	45.4(100)	54.4(120)	67.9(150)	77.1(170)	86(190)	90(200)
Basket Diameter	mm.	inch	762(30")	922(36.3")	922(36.3")	1130(44.5")	1130(44.5")	1308(51.5")	1308(44.5")	1308(51.38")	1500(59")
Basket Depth	mm.	inch	762(30")	762(30")	910(35.8")	867(32.4")	1076(42.4")	960(37.8")	1080(42.5")	1270(50")	1190(46.85")
Basket Volume	cu.m	cu.ft	0.35(12.4)	0.51(18)	0.61(21.5)	0.78(30.7)	1.08(38.1)	1.29(45.6)	1.45(51.2)	1.71(60.4)	2.1(74.16)
Basket Motor	kW	HP	0.373(0.5)	0.75(1)	0.75(1)	0.75(1)	0.75(1)	1.5(2)	1.5(2)	2.24(3)	2.24(3)
Blower Motor	kW	HP	0.373(0.5)	0.75(1)	0.75(1)	2.24(3)	2.24(3)	5.5(7.5)	5.5(7.5)	5.5(7.5)	5.5(7.5)
<b>Overall Dimensions :</b>											
A - Machine Width	mm.	inch	805(31.7")	975(38.4")	980(38.6")	1200(47.2")	1200(47.2")	1420(55.9")	1420(55.9")	1416(55.7")	1616 (63.6")
B - Machine Depth	mm.	inch	1140(44.9")	1150(45.3")	1270(50")	1451(57.1")	1660(65.4")	1601(63")	1700(66.9")	1970(77.6")	2027(79.8")
C - Machine Height at full	mm.	inch	1740(68.5")	1920(75.6")	1920(75.6")	2090(82.3")	2090(82.3")	2380(93.7")	2380(93.7")	2380(93.7")	2530(99.6")
<b>Gas Model :</b>											
Air Flow	cmm	cfm	17(600)	21.25(750)	25.5(900)	62.3(2200)	62.3(2200)	70.8(2500)	113.27(4000)	113.27(4000)	150(5300)
Gas Consumption	kcal/hr	btu/hr	22680(90000)	32760(130000)	50400(200000)	94500(375000)	94500(375000)	123480(490000)	138700(550000)	157600(625000)	157600(625000)
Gas Inlet Connection	NPT		1/2"	1/2"	3/4"	1"	1"	1"	1"	1"	1"
Exhaust Duct Connection	mm.	inch	203(8")	203(8")	203(8")	305(12")	305(12")	406(16")	406(16")	406(16")	406(16")
Net Weight (approx.)	kg.	lbs.	294(648.2)	348(767.2)	379(835.5)	596 (1254.4)	682(1503.6)	896(1975.3)	1016(2239.9)	1150(2535.3)	1216(2681)
Shipping Weight	kg.	lbs.	304(670.2)	358(789.3)	390(859.8)	616(1358.0)	702(1547.6)	922(2028.4)	1046(2306)	1180(2601.5)	1246(2747)
<b>Steam Model:</b>											
Air Flow	cmm	cfm	17(600)	21.25(750)	25.48(900)	77.9(2750)	77.9(2750)	113.26(4000)	113.26(4000)	184(6500)	184(6500)
Steam Consumption	kg/hr	lb/hr	40.69(89.7)	71.99(158.7)	101.125(224.25)	203.45(448.5)	203.45(448.5)	297.35(655.5)	297.35(655.5)	422.55(931.5)	422.55(931.5)
Steam Supply Connection	NPT		3/4"	3/4"	3/4"	1"	1"	1"	1"	2"	2"
Steam Return Connection	NPT		1/2"	1/2"	1/2"	3/4"	3/4"	3/4"	3/4"	1-1/4"	1-1/4"
Exhaust Duct Connection	mm.	inch	203(8")	203(8")	203(8")	305(12")	305(12")	406(16")	406(16")	406(16")	406(16")
Steam Pressure	bar	Psi	5.6-8.79(80-125)	5.6-8.79(80-125)	5.6-8.79(80-125)	5.6-8.79(80-125)	5.6-8.79(80-125)	5.6-8.79(80-125)	5.6-8.79(80-125)	5.6-8.79(80-125)	5.6-8.79(80-125)
Air Pressure	bar	Psi	N/a	N/a	N/a	N/a	6-8(87-116)	6-8(87-116)	6-8(87-116)	6-8(87-116)	6-8(87-116)
Net Weight (approx.)	kg.	lbs.	307(676.9)	362(798)	385(848.8)	609(1342.6)	731(1611.6)	919(2026)	1042(2297.2)	1180(2601.5)	1229(2709.5)
Shipping Weight (approx.)	kg.	lbs.	315(694.5)	372(820.1)	396(873.0)	629(1386.7)	751(1655.7)	949(2092.2)	1072(2363.4)	1210(2667.6)	1269(2797.7)
<b>Electric Model :</b>											
Air Flow	cmm	cfm	17(600)	21.25(750)	25.48(900)	77.9(2750)	77.9(2750)	113.26(4000)	113.26(4000)	184(6500)	184(6500)
Electrical Heating Power	kW		24	24	36	72	72	120	120	120	120
Exhaust Duct Connection	mm.	inch	203(8")	203(8")	203(8")	305(12")	305(12")	406(16")	406(16")	406(16")	406(16")
Net Weight (approx.)	kg.	lbs.	308(679)	354(780.4)	382(842.2)	558(1230.2)	702(1547.6)	905(1995)	1026(2261.9)	N/a	1331(2934.4)
Shipping Weight (approx.)	kg	lbs.	317(698.9)	364(802.5)	393(866.4)	578(1274.3)	722(1591.7)	932(2054)	1056(2328.1)	N/a	1371(3022.5)

FRONT VIEW

SIDE VIEW

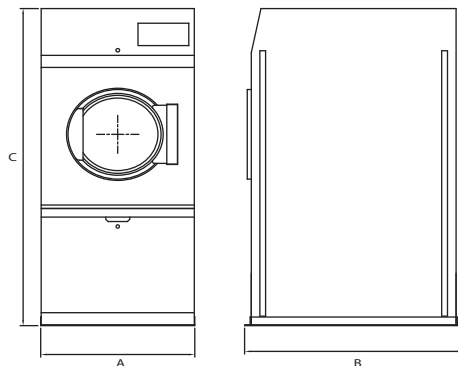

Intertek



Iron Horse Laundry

American Global Trade and Tech LLC

Address: 1621 Central Ave Cheyenne WY 82001, Wyoming State USA

Phone: 307-637-5151 / Fax: 307-637-5152

E-mail:sales@ironhorselaundry.com /www.ironhorselaundry.com

ISO 9001 : 2008

ISO 13485 : 2016